

# SAND WASHER SW SERIES

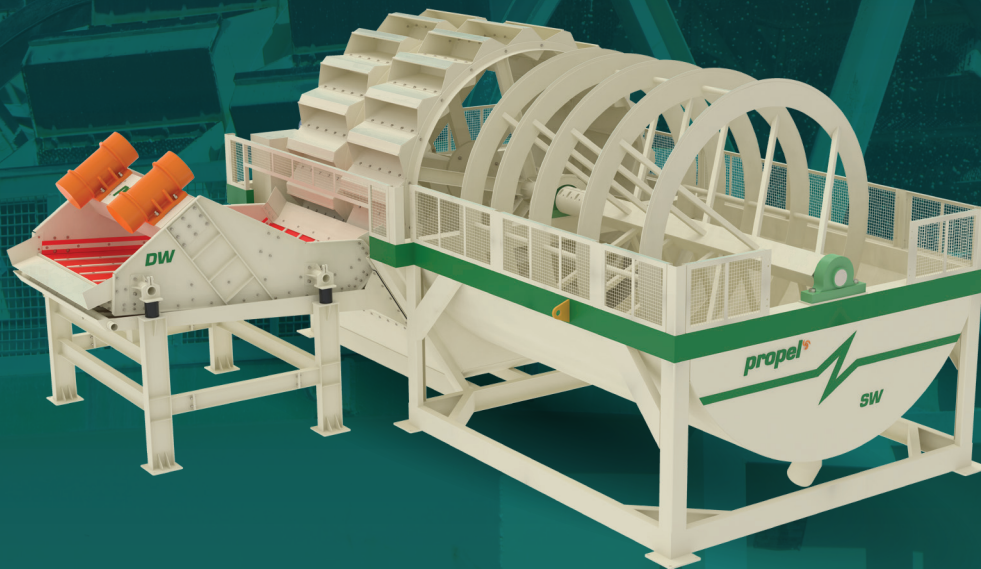

Bucket type sand washing equipment can improve the sand quality. Propel Sand Washers adopt advanced technology for high efficiency sand washing.

## FEATURES

- ✓ Cartridge type bucket wheel and spiral arrangement bucket speed controlled by VFD to control percentage of fines.
- ✓ High-tech planetary gear reducer is used for better and efficient maintenance.
- ✓ Spiral wheels empowered with sail hard liners for wear resistant and long life.
- ✓ Total water trough is protected by anti-corrosive coating.
- ✓ High frequency dewatering screens with polyurethane modular mats.



Bucket speed controlled by a Variable Frequency Drive (VFD)



Total water trough is protected by anti-corrosive coating.

**Propel. Always Ahead.**

# TECHNICAL DATA

Series		SW 75	SW 100	SW 150	SW 200
*Capacity	TPH	45 - 60	60 - 80	90 - 120	120 - 160
Wheel diameter	m	2.27	2.5	2.75	3.1
Number of buckets	No's	34	36	42	42
Screw Diameter	mm (inch)	1800 (71.0)	1700 (67.0)	2200 (86.6)	2800 (110.2)
Water Tank Capacity	ltrs	4500	5000	6000	8000
Motor Power	kW (hp)	5.5 (7)	7.5 (10)	9.3 (12)	9.3 (12)
Weight	kg (Ton)	3600 (3.6)	5200 (5.2)	7100 (7.1)	8500 (8.5)

## DEWATERING SCREEN

Series		SDW 75	SDW 100	SDW 150	SDW 200
Screen Area (Wx L)	mm (Inch)	900 x 1800 (35.4 x 71.0)	1200 x 2150 (47.2 x 84.6)	1500 x 2500 (59.1 x 98.4)	1800 x 2500 (71.0 x 98.4)
*Capacity	TPH	45 - 60	60 - 80	90 - 120	120 - 160
Operating Angle	deg	5°	5°	5°	5°
Motor Power	kW (hp)	2 x 1.13 (2 x 2)	2 x 1.5 (2 x 2)	2 x 2.2 (2 x 3)	2 x 3.2 (2 x 4)
Weight	kg (Ton)	775 (0.77)	850 (0.85)	1300 (1.3)	1900 (1.9)

\*Details may vary based on application

Note: All the above technical details may vary at any time during engineering process & design development

# DIMENSIONS

Model	Units	A	B	C
SW75	mm	5775	4685	2566
SW100	mm	6830	5406	3086
SW150	mm	7900	5777	3206
SW200	mm	8510	6145	3485

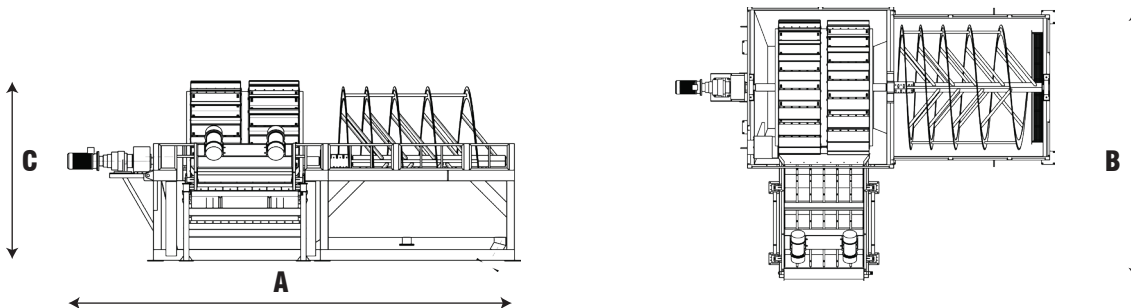

# GET IN TOUCH

**Corporate Office:**  
**PROPEL INDUSTRIES PVT LTD**  
 SF NO : 38/1B, Trichy Main Road,  
 Kangayampalayam, Sulur,  
 Coimbatore - 641 401. India.

**Dealer Office:**  
**Heavy Machinery Viqa,**  
 Saih Shuaib 4, Roundabout 6  
 Dubai Industrial City, Dubai  
 United Arab Emirates

**Communication**  
 +971 800 MYHVMV / +971 50 275 0508  
 Email: sales@hvmachinery.com  
 www.hvmachinery.com

