

VERTICAL SHAFT IMPACTOR AVVI SERIES



Propel Vertical Shaft Impactor has been developed with inputs from aggregate producers. The high-velocity impact crusher in Propel VSI enhances the shape of the aggregates and improves the surface structure. It is suitable for all types of materials.

FEATURES

- ✓ Steel structure for smooth operation. Simple inter-changeable cartridge type rock box for 'rock-on-rock' applications.
- ✓ Hydraulic feed control In-built device. Parallel flow system provides increased capacity and less micro fines content.
- ✓ Due to better shaping, the voids are taken care of, resulting in less consumption of cement. Propel Vertical Shaft Impactor produces shapes as per the Ministry of Road Transport & Highways (MORTH) standards.
- ✓ Crusher impact combined with speed gives the unique shape resulting in production of high-quality manufactured sand confirming to C 144 standards.



Unbeatable
Performance



Crusher impact and
speed yield fine sand
meeting C 144 standards.

Propel. Always Ahead.

TECHNICAL DATA

Series		AVVI 55	AVVI 75	AVVI 90	AVVI 110	AVVI 130	AVVI 160
Feed Size (Max.)	mm (inch)	32 (1.3)	32 (1.3)	43 (1.7)	43 (1.7)	43 (1.7)	43 (1.7)
*Capacity	TPH	40 - 80	50 - 110	60-120	80-140	100-160	130-190
Rotar Diameter	mm (inch)	680 (26.8)	680 (26.8)	710 (28.0)	710 (28.0)	710 (28.0)	710 (28.0)
Rotar Speed	m/sec	45 - 60	45 - 70	45 - 70	45 - 70	45 - 70	45 - 70
Impact Cartridge Options		Rock-on-Rock					
Port Options		3 / 4					
Lubrications		Grease					
Motor Power	kW (hp)	55 (75)	75 (100)	90 (120)	110 (150)	132 (177)	160 (150)
Weight	kg (Ton)	4200 (4.2)	4600 (4.6)	6400 (6.4)	6600 (6.6)	6600 (6.6)	6800 (6.8)

Series		AVVI 190	AVVI 220	AVVI 260	AVVI 320	AVVI 375	AVVI 450	AVVI 500	AVVI 630
Feed Size (Max.)	mm (inch)	58 (2.3)	58 (2.3)	58 (2.3)	58 (2.3)	66 (2.6)	66 (2.6)	66 (2.6)	66 (2.6)
*Capacity	TPH	120-260	150-290	180-340	240-400	265-485	340-560	400-600	530-730
Rotar Diameter	mm (inch)	880 (34.6)	880 (34.6)	880 (34.6)	880 (34.6)	990 (39.0)	990 (39.0)	990 (39.0)	990 (39.0)
Rotar Speed	m/sec	45-70	45-70	45-70	45-75	45-75	45-75	45-75	45-75
Impact Cartridge Options		Rock-on-Rock / Rock-on-Anvil							
Port Options		3 / 4 / 5							
Lubrications		Grease							
Motor Power	kW (hp)	187 (250)	220 (300)	2 x 132 (2 x 175)	2 x 160 (2 x 215)	2 x 187 (2 x 250)	2 x 220 (2 x 300)	2 x 250 (2 x 335)	2 x 315 (2 x 425)
Weight	kg (Ton)	9700 (9.7)	9700 (9.7)	11500 (11.5)	11600 (11.6)	14200 (14.2)	15400 (15.4)	15400 (15.4)	15400 (15.4)

DIMENSIONS

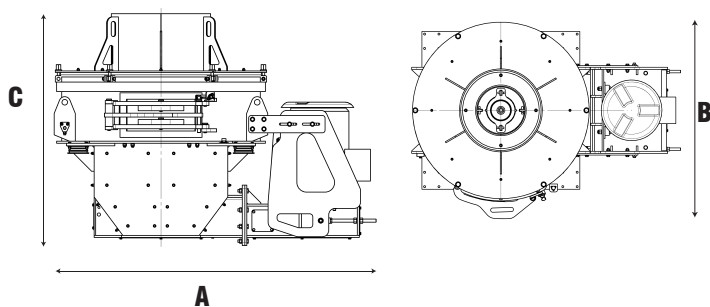

Model	Units	A	B	C
AVVI 55	mm	2520	1847	1822
AVVI 75	mm	2520	1847	1822
AVVI 90	mm	2828	2094	2204
AVVI 110	mm	2828	2094	2204
AVVI 130	mm	2828	2094	2204
AVVI 160	mm	2828	2094	2204
AVVI 190	mm	3195	2414	2480
AVVI 220	mm	3195	2414	2480
AVVI 260	mm	4272	2414	2480
AVVI 320	mm	4272	2414	2480
AVVI 375	mm	4456	2462	2937
AVVI 450	mm	4456	2642	2937
AVVI 500	mm	4456	2642	2937
AVVI 630	mm	4456	2642	2937

GET IN TOUCH

Corporate Office:
PROPEL INDUSTRIES PVT LTD
 SF NO : 38/1B, Trichy Main Road,
 Kangayampalayam, Sullur,
 Coimbatore - 641 401. India.

Dealer Office:
Heavy Machinery Viqa,
 Saih Shuaib 4, Roundabout 6
 Dubai Industrial City, Dubai
 United Arab Emirates

Communication
 +971 800 MYHVMV / +971 50 275 0508
 Email: sales@hvmachinery.com
 www.hvmachinery.com

