

HORIZONTAL SHAFT IMPACTOR AVHI SERIES

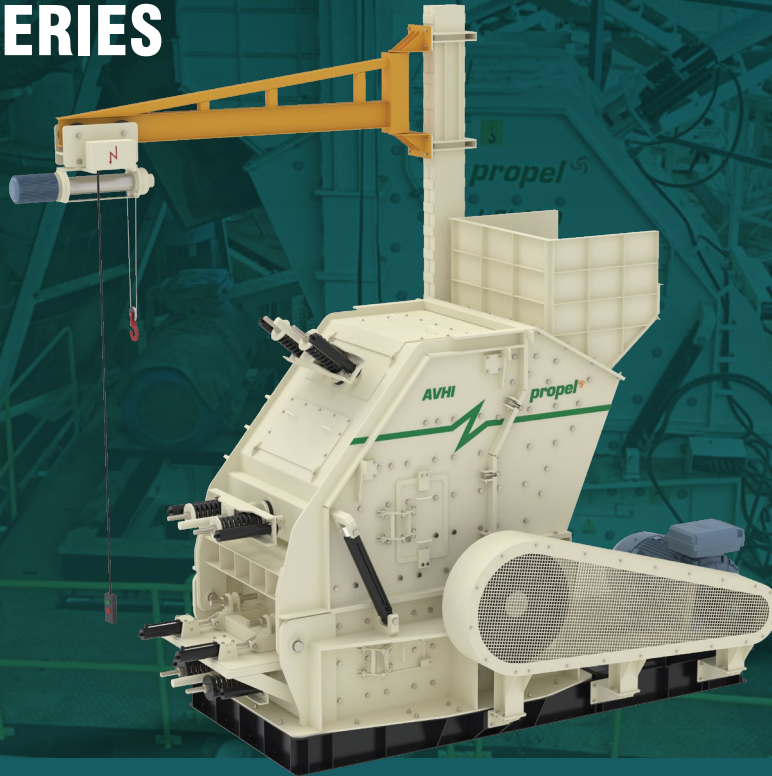

Horizontal Shaft Impactor delivers high reliability. It has high efficiency belt drive and hydraulic gap management. It is designed for Limestone, Dolomite, Gravel, Glass, Sandstone, Salt, Gypsum and Potash.



FEATURES

- ✓ Hydraulic adjustable curtain design, easily removable and replaceable blow bars.
- ✓ Large feed opening, maximum performance rotor.
- ✓ Hydraulic crusher housing, high reduction ratio.
- ✓ Durable Construction, robust and reliable design.
- ✓ Hydraulic arrangement maintains operating gap to ensure desired output size.



Robust & Reliable
Design



High performance rotor

Propel. Always Ahead.

TECHNICAL DATA

Series		AVHI 250	
Feed Opening (Max.)	mm (inch)	1400 x 600 (55.1 x 23.6)	
Feed Size (Max.)	mm (inch)	350 (13.8)	
*Capacity	TPH	160 - 300	
Rotor Speed	rpm	550 - 620	
CSS Settings		Range	Optimum
Apron 1	mm	250 - 10	120
Apron 2	mm	130 - 10	90
Grinding Path Top	mm	130 - 10	60
Grinding Path Bottom	mm	80 - 10	30
Lubrication	Pressurized Grease		
Construction	High Grade Carbon Steel Plate (IS:2062)		
Mounting Type (optional)	Skid		
Motor Power	Kw (hp)	220 (295)	
Weight	Kg (ton)	23800 (23.8)	

*Details may vary based on application

Note: All the above technical details may vary at any time during engineering process & design development

DIMENSIONS

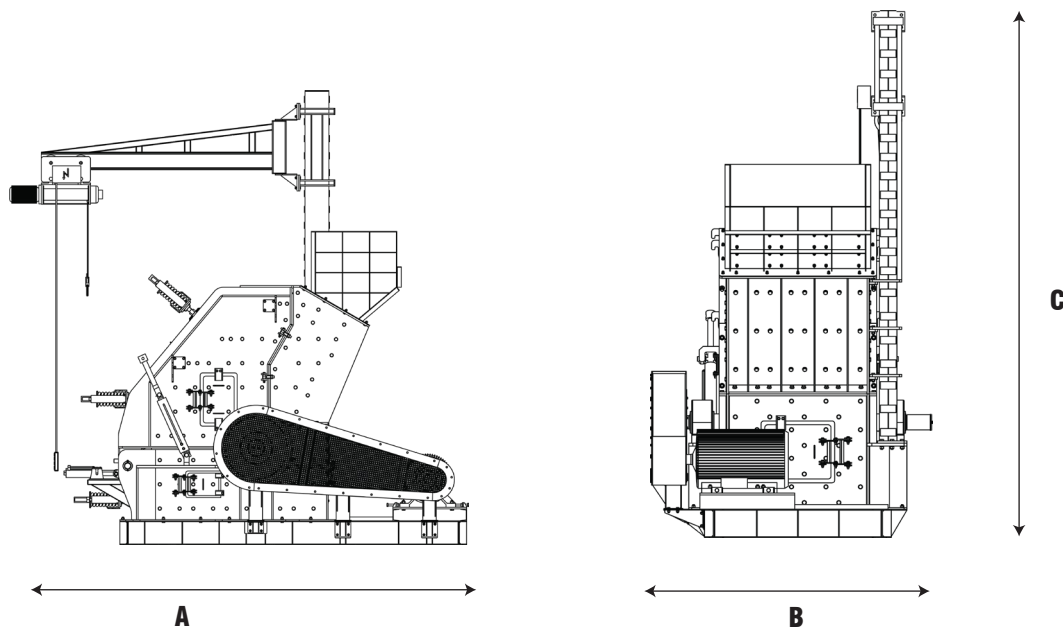

GET IN TOUCH

Corporate Office:
SF NO : 38/1B, Trichy Main Road,
Kangayampalayam, Sullur,
Coimbatore - 641 401. India.

Communication :
+91 99940 60001 / 99940 60002
Email : marketing@propelind.com
Web : www.propelind.com

