

CONE CRUSHER AVC SERIES



The AVC Series of Propel Cone Crusher offers the higher crushing efficiency and end product quality with lower cost per ton production. These crushers feature a unique combination of crusher speed, throw and cavity design.



FEATURES

- ✓ Dual-dust seal system. User-friendly SMS system.
- ✓ Bigger mantle diameter combined with effective speed to enhance productivity.
- ✓ Availability of specially defined chambers to crush coarse/fine feed materials and also to cover open / closed circuit.
- ✓ User-friendly SMS system.



Unbeatable
Performance



Hydraulic
Setting
Adjustment



High Alloy
Bronze Bearing
Design

Propel. Always Ahead.

TECHNICAL DATA

COARSE CHAMBER

Series		AVC 125	AVC 160	AVC 220	AVC 250	AVC 350
Feed Opening	mm (inch)	145 (5.7)	180 (7.1)	220 (8.7)	230 (9.1)	EC 250 C 200 (9.8) (7.9)
Feed Size (Max.)	mm (inch)	120 (4.7)	150 (6.0)	190 (7.5)	200 (7.9)	EC 220 C 180 (8.7) (7.1)
*Capacity	TPH	80-110	100-225	140-320	160-340	300 - 400
CSS Range	mm (inch)	22 - 30 (0.9 - 1.2)	24 - 32 (0.9 - 1.3)	24 - 35 (0.9 - 1.4)	26 - 35 (1.0 - 1.4)	20 - 45 (0.8 - 1.8)
Mounting Type (Optional)		Skid	Skid	Skid / Wheel Mounted / Crawler Mounted		
Motor Power	kW (hp)	75 (100)	110 (150)	160 (215)	187 (250)	220 - 315 (295 - 422)
Weight	kg (Ton)	6500 (6.5)	10000 (10.0)	13300 (13.3)	13300 (13.3)	16600 (16.6)

Design Type : Bush Type

Lubrication : Pressurized oil & grease

Construction : High grade carbon steel c

FINE CHAMBER

Series		SM 100	SM 150	SM 200	SM 250	SM 320
Feed Opening	mm (inch)	50 (2.0)	75 (3.0)	95 (3.7)	95 (3.7)	95 (3.7)
Feed Size (Max.)	mm (inch)	45 (1.8)	60 (2.4)	75 (3.0)	75 (3.0)	80 (3.1)
*Capacity	TPH	60-90	85-140	120-185	150-240	230-320
CSS Range	mm (inch)	12 - 28 (0.5 - 1.1)	12 - 28 (0.5 - 1.1)	14 - 28 (0.5 - 1.1)	14 - 35 (0.5 - 1.4)	10 - 25 (0.4 - 1.0)
Mounting Type (Optional)		Skid	Skid	Skid / Wheel Mounted / Crawler Mounted		
Motor Power	kW (hp)	75 (100)	110 (150)	160 (215)	187 (250)	220-250 (295)
Weight	kg (Ton)	6600 (6.6)	10100 (10.1)	13400 (13.4)	13500 (13.5)	16300 (16.3)

Design Type : Bush Type

Lubrication : Pressurized oil & grease

Construction : High grade carbon steel c

DIMENSIONS

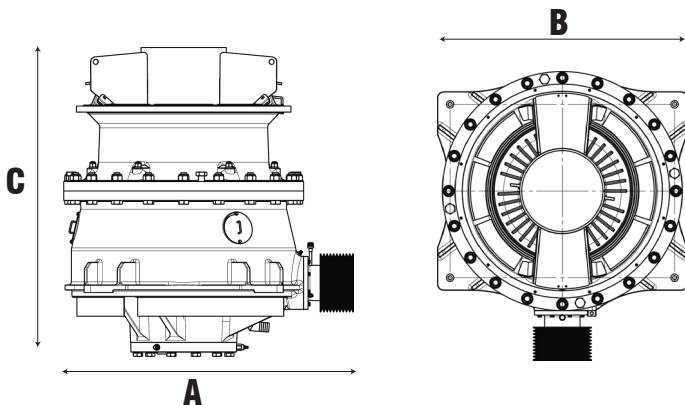

Model	Units	A	B	C
AVC-125	mm	1593	1470	2120
AVC-160	mm	1810	1800	2375
AVC-220	mm	2065	2018	2623
AVC-250	mm	2065	2018	2623
AVC-350	mm	2296	1978	2451
AVC-350 WT BASE FRAME	mm	3488	2424	2793
SM-100	mm	1593	1470	2120
SM-150	mm	1810	1800	2375
SM-200	mm	2065	2018	2623
SM-250	mm	2065	2018	2623
SM-320	mm	2296	1978	2451

GET IN TOUCH

Corporate Office:
PROPEL INDUSTRIES PVT LTD
 SF NO : 38/1B, Trichy Main Road,
 Kangayampalayam, Sullur,
 Coimbatore - 641 401. India.

Dealer Office:
Heavy Machinery Viqa,
 Saih Shuaib 4, Roundabout 6
 Dubai Industrial City, Dubai
 United Arab Emirates

Communication
 +971 800 MYHVMV / +971 50 275 0508
 Email: sales@hvmachinery.com
 www.hvmachinery.com

