

TRACK MOUNTED ENDURER QM SERIES



Propel QM 250 S is designed to maximise throughput and product shape in a wide range of crushing applications. The inclusion of a plant mounted double deck vibrating screen allows for oversize material to be re circulated for re crushing and for sized end products. Its cost effectiveness is justified by its low fuel consumption, low operating and maintenance costs as well as high capacity and environmental friendly.

FEATURES

- ✓ Heavy duty track unit with dual speed configuration.
- ✓ Safety guards in compliance with machinery directive. Sturdy walkway with handrails, kick board and access ladders.
- ✓ Dual power mode - flexibility to power the plant either by external electric connection or by on-board diesel generator power pack unit (optional).
- ✓ Radio remote control for marching (optional). Feed level sensor for crusher.
- ✓ PLC drive, Metal detector and Sensor control system & four-point emergency stop.
- ✓ Electrical driven hydraulic system for quick setup & marching. Low noise acoustic engine canopy with overload protection.



Propel. Always Ahead.

TECHNICAL DATA

Series		TMC SQM 230 S	TMC QM 250 S
Feed Opening	mm (inch)	85 (3.3)	220 (8.7)
CSS Range	mm (inch)	15-30 (0.6-1.2)	26 - 45 (1.0 - 1.8)
*Capacity	TPH	125-250	150 - 380
Hopper / Feeder			
Hopper Capacity	m ³	6	6
Feed Belt Width (mm)	mm	1000	1000
Main Conveyor			
Belt Width	mm	1000	1000
Top / Bottom Deck Transfer Conveyor			
Belt Width	mm	500	500
Stock pile / Recycling Conveyor			
Belt Width	mm	500	500
Fines Conveyor			
Belt Width	mm	1400	1400
On Board Screen			
Deck Size	mm (inch)	1800 x 3700 (70.9 x 145.7)	1800 x 3700 (70.9 x 145.7)
Number of Decks	mm	2	2
Under Carriage			
Shoe Width	mm	500	500
Hydraulic Tank Capacity	Ltrs	435	435
Power Unit			
Engine		Scania DC13 Engine With Alternator	
Diesel Tank Capacity	Ltrs	720	720
Dimension			
Transport (L x W x H)	mm (inch)	19310 x 3450 x 4150 (760.2 x 135.8 x 163.4)	19310 x 3450 x 4150 (760.2 x 135.8 x 163.4)
Working (L x W x H)	mm (inch)	19450 x 12360 x 5145 (765.7 x 486.6 x 202.5)	19450 x 12360 x 5145 (765.7 x 486.6 x 202.5)
**Weight	Kg (Ton)	58500 (58.5)	58500 (58.5)

*Details may vary based on application

Note: All the above technical details may vary at any time during engineering process & design development

Model	Units	A	B	C
TMC SQM 230 S	mm	19450	12360	5145
TMC QM 250 S	mm	19450	12360	5145

DIMENSIONS

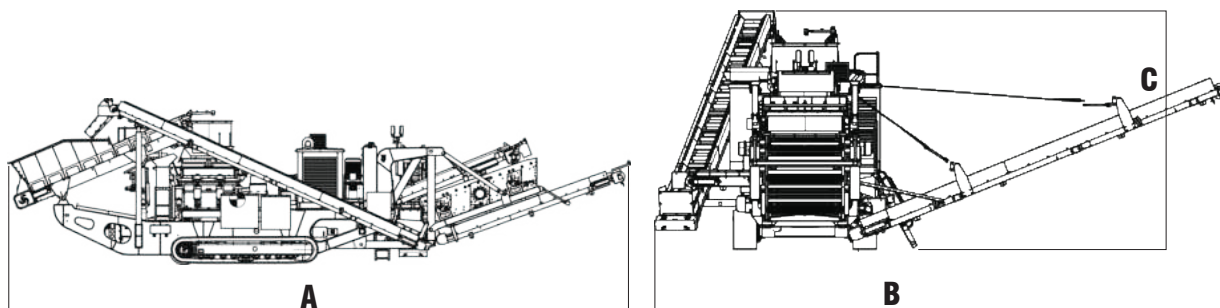

GET IN TOUCH

Corporate Office:
PROPEL INDUSTRIES PVT LTD
 SF NO : 38/1B, Trichy Main Road,
 Kangayampalayam, Sullur,
 Coimbatore - 641 401. India.

Dealer Office:
Heavy Machinery Viqa,
 Saih Shuaib 4, Roundabout 6
 Dubai Industrial City, Dubai
 United Arab Emirates

Communication
 +971 800 MYHVMV / +971 50 275 0508
 Email: sales@hvmachinery.com
 www.hvmachinery.com



PRO_IND_09_24_R1