

## TRACK MOUNTED CONE TMC AVC SERIES



Propel AVC Series Cone crusher feature a unique combination of crusher speed, throw and cavity design. This combination is known for its revolutionary higher capacity and better product quality. It has been designed to ensure trouble-free operation in heavy and continu-

### FEATURES

- ✓ Heavy duty track unit with dual speed (optional) configuration.
- ✓ Safety guards in compliance with machinery directive. Sturdy walkway with handrails, kick board and access ladders.
- ✓ Dual power mode - flexibility to power the plant either by external electric connection or by on-board diesel generator power pack unit (optional).
- ✓ Four-point emergency stop. Detachable dog lead control system for marching.
- ✓ Radio remote control for marching (optional). Feed level sensor for crusher (optional).
- ✓ Electrical driven hydraulic system for quick setup & marching. Low noise acoustic engine canopy with overload protection.



***Propel. Always Ahead.***

# TECHNICAL DATA

Series		TMC 220	TMC 250	SM 200	SM 250
Feed Opening	mm (inch)	220 (8.7)	230 (9)	95 (3.7)	95 (3.7)
CSS Range	mm (inch)	24-35 (0.9-1.4)	26-35 (1 -1.4)	14-28 (0.6-1.1)	14-30 (0.6-1.2)
*Capacity	TPH	140-320	160-340	120-185	150-240
Hopper / Feeder					
Hopper Capacity	m <sup>3</sup>	6	6	6	6
Feed Belt Width ( mm )	mm	1000	1000	1000	1000
Main Conveyor					
Belt Width	mm	1000	1000	1000	1000
Discharge Height	mm	3600	3600	3600	3600
Stock Pile Capacity	m <sup>3</sup>	69.4 @ 40°	69.4 @ 40°	69.4 @ 40°	69.4 @ 40°
Under Carriage					
Shoe Width	mm	500	500	500	500
Hydraulic Tank Capacity	Ltrs	390	390	390	390
Power Unit					
Engine	Scania DC09 Engine With Alternator CAT C9.3B Engine With Alternator   Cummins QSL9 Engine With Alternator.				
Diesel Tank Capacity	Ltrs	500	500	500	500
Dimension					
Transport ( L x W x H )	mm (inch)	15810X3400X4050 (622.4 x 133.9 x 159.4)	15810X3400X4050 (622.4 x 133.9 x 159.4)	15810X3400X4050 (622.4 x 133.9 x 159.4)	15810X3400X4050 (622.4 x 133.9 x 159.4)
Working ( L x W x H )	mm (inch)	17815X4760X4800 (701.4X187.4X189)	17815X4760X4800 (701.4X187.4X189)	17815 x 4760 x 4800 (701.4 x 187.4 x 189.0)	17815 x 4760 x 4800 (701.4 x 187.4 x 189.0)
**Weight	Kg (Ton)	48000(48.0)	48000(48.0)	48000(48.0)	48000(48.0)

\*Details may vary based on application

Note: All the above technical details may vary at any time during engineering process & design development

Model	Units	A	B	C
TMC 220	mm	17815	4760	4800
TMC 250	mm	17815	4760	4800
TMC SM 200	mm	17815	4760	4800
TMC SM 250	mm	17815	4760	4800

## DIMENSIONS

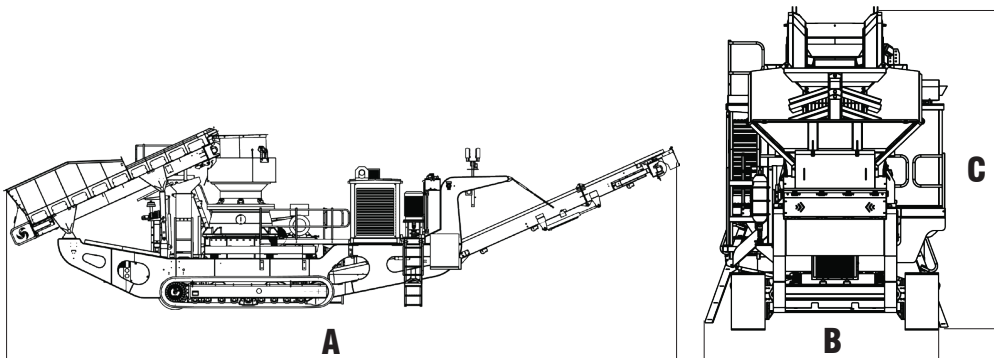

## GET IN TOUCH

**Corporate Office:**  
**PROPEL INDUSTRIES PVT LTD**  
 SF NO : 38/1B, Trichy Main Road,  
 Kangayampalayam, Sullur,  
 Coimbatore - 641 401. India.

**Dealer Office:**  
**Heavy Machinery Viqa,**  
 Saih Shuaib 4, Roundabout 6  
 Dubai Industrial City, Dubai  
 United Arab Emirates

**Communication**  
 +971 800 MYHMV / +971 50 275 0508  
 Email: sales@hvmachinery.com  
 www.hvmachinery.com

