

TRACK MOUNTED JAW TMJ - AVJ 811



The elevated mouth opening of the TMJ Series single toggle Jaw Crushers ensure significant production saving by eliminating frequent bridging of stone in feed opening. Optimum jaw nip angle reduces laminar product shape, ensures even manganese wear-off with increasing production.



FEATURES

- ✓ Heavy duty track unit with dual speed (optional) configuration.
- ✓ Safety guards in compliance with machinery directive. Sturdy walkway with handrails, kick board and access ladders.
- ✓ Dual power mode - flexibility to power the plant either by external electric connection or by on-board diesel generator power pack unit (optional).
- ✓ Four-point emergency stop. Detachable dog lead control system for marching.
- ✓ Radio remote control for marching (optional). Feed level sensor for crusher (optional).
- ✓ Electrical driven hydraulic system for quick setup & marching. Low noise acoustic engine canopy with overload protection.

Propel. Always Ahead.

TECHNICAL DATA

Series		TMJ 811
Opening Size (W x L)	mm (inch)	750 x 1064 (29.5 x 41.9)
CSS Range	mm (inch)	75 to 200 (3.0 to 8.0)
*Capacity	TPH	150 - 400
Hopper / Feeder		
Hopper Capacity	m ³	10
Grizzly Feeder AVGF 1142 V2		
Size	mm (inch)	1100 x 4200 (43.3 x 165.3)
Main Conveyor		
Belt Width	mm	1000
Discharge Height	mm	3700
Stock Pile Capacity	m ³	75 @ 40°
Bypass Conveyor		
Belt Width	mm	650
Discharge Height	mm	2100
Stock Pile Capacity	m ³	13.7 @ 40°
Under Carriage		
Shoe Width	mm	500
Hydraulic Tank Capacity	Ltrs	390
Power Unit		
Engine		Scania DC09 Engine With Alternator CAT C9.3B Engine With Alternator Cummins QSL9 Engine With Alternator.
Diesel Tank Capacity	Ltrs	500
Dimension		
Transport (L x W x H)	mm (inch)	15350 x 3460 x 4100 (604.3x 136.2 x 161.4)
Working (L x W x H)	mm (inch)	15940 x 4850 x 4900 (627.5 x 190.9 x 192.9)
**Weight	Kg (Ton)	55000 (55.0)

*Details may vary based on application

Note: All the above technical details may vary at any time during engineering process & design development

DIMENSIONS

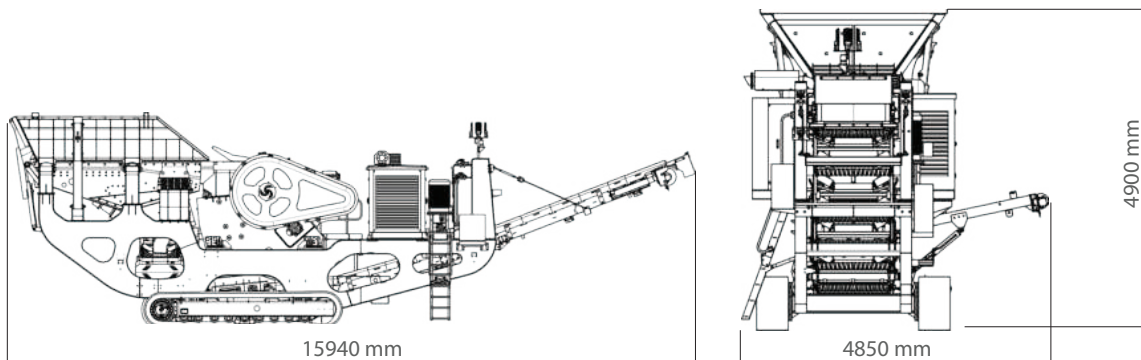

GET IN TOUCH

Corporate Office:
PROPEL INDUSTRIES PVT LTD
 SF NO : 38/1B, Trichy Main Road,
 Kangayampalayam, Sulur,
 Coimbatore - 641 401. India.

Dealer Office:
Heavy Machinery Viqa,
 Saih Shuaib 4, Roundabout 6
 Dubai Industrial City, Dubai
 United Arab Emirates

Communication
 +971 800 MYHMV / +971 50 275 0508
 Email: sales@hvmachinery.com
 www.hvmachinery.com

